



ELECTRO **BRAID**™ **FENCE** Patented

**READ THE FOLLOWING
INFORMATION CAREFULLY.**

**Failure to follow these instructions
could result in injury to persons
and/or livestock.**

Installation Manual

Published January 15, 2006

The Largest Selling Electric Horse Fence

Congratulations on your decision to purchase an ElectroBraid™ Fence for your horses. We know you will be extremely pleased with ElectroBraid's ease of installation, minimal maintenance, safety and performance. Hundreds of hours have gone into testing all the items in our system to ensure high quality.

This installation manual can help you properly install your ElectroBraid™ Fence. It is **IMPORTANT** you follow these instructions to minimize maintenance and maximize safety.

We have tried to include as much detail as possible; however, it is impossible to cover every application. If you have a question, please call and we will do our best to assist you.

Call us toll free at **877.300.2638** or by e-mail at **info@electrobraidfence.com**.

It is our commitment to you and to your horses, to provide a safe, reliable and cost effective Fence System.

Thank you for choosing ElectroBraid®. We look forward to serving you now and in the future.

Our Company Mission is to Build Safe Fences for Horses

Table of Contents

ElectroBraid’s Commitment to Safety.....	4
Five Steps to Successful Fencing.....	5
Planning your ElectroBraid® Fence.....	6
What you will Need	7
Tools Required	9
Getting Started – Line Spacing.....	10
Installing Corner and End Posts/Braces.....	10
Installing Insulators on Corner, End and Gate Posts	13
Installing ElectroBraid® Roller Insulators on Inside Corners	14
Using Trees For Corner, End and Line Posts	14
Installing Line Posts	15
<i>Installing Wood Line Posts</i>	16
<i>Installing T-Post Line Posts.....</i>	16
<i>Installing Geotek Fiberglass Line Posts.....</i>	16
Running your Lines.....	17
Tension Kit Assembly	18
Tensioning ElectroBraid®.....	18
Splicing ElectroBraid®.....	20
Electrifying the Fence	21
<i>Choosing your Energizer</i>	21
<i>Ground System</i>	22
<i>Wiring your Energizer.....</i>	24
<i>Wiring the Energizer for Areas of High Snowfall</i>	25
<i>When to Wire Gates.....</i>	26
<i>Wiring Gates.....</i>	26
<i>Wiring Gates in Areas of High Snowfall</i>	27
<i>Using Gate Handles for Gates.....</i>	28
<i>Wiring Cross Fencing Sections (paddock division).....</i>	29
Testing the Voltage on Your Fence.....	29
Diagnosing Electrification Problems.....	29
Trouble Shooting	31
Installing an ElectroBraid® Fence Minder.....	32
Do’s & Don’ts – Safety and Maintenance.....	33
Hiring a Professional Fence Installer.....	36

ElectroBraid's Commitment to Safety

The ElectroBraid® System is designed to minimize injuries to horses.

Equally important, you must provide correct installation and proper maintenance.

A collision with a rigid fence is the most frequent cause of serious horse injury. ElectroBraid® is not rigid, it is resilient, like a boxing ring. When a horse at full gallop impacts ElectroBraid®, it usually bounces right back, with no damage to horse or fence.

ElectroBraid® is a psychological barrier. Always maintain at least 5,000 volts and a good grounding system to ensure your horse will receive a significant electric shock – not just a “bee-sting.” The shock from a UL or CSA approved energizer won't harm your horse, because the shock is very low amperage for a tiny fraction of a second, but your horse will always respect ElectroBraid® in future.

You can buy and install an ElectroBraid Fence Minder® which will continuously monitor your fence. It will warn you day or night if it detects a significant voltage drop. If a horse is in contact with your fence for more than 3 seconds, your Fence Minder® will turn off your energizer to stop further shocks; and immediately alert you by siren or by auto-dialing your choice of telephone numbers.

Injuries with ElectroBraid® are very rare. If an incident occurs, please call 1-888-430-3330 so we can discuss the circumstances with you. Hopefully, we can together take corrective action to prevent any future injury.

Our Company Mission is To Build Safe Fences for Horses.

Any Questions? Call us Toll-Free at 1-888-430-3330.

We are always pleased to help.



Five Steps to Successful Electric Fencing

1) The Right Energizer for the Job

There are a variety of energizers on the market but we only recommend low impedance energizers certified safe by UL or CSA. They put out a very short, low amperage pulse of electricity, which will not harm an animal or child. NEVER use “Weed Burners” or “Weed Choppers” – these energizers have been banned in many areas as a fire and safety hazard and will damage ElectroBraid™.

2) Install a Good Ground System

Poor or improper grounding causes 95% of all electric fencing problems. You can have the most powerful energizer in the world, but if the ground return is poor, your fence will not perform. Use a minimum of three six-foot long copper clad ground rods spaced at least 10 feet apart. With dry or sandy soil, you may need more ground rods. When you wire your fence, ground the second-from-the-top strand of Braid™ and electrify the remaining strands of Braid™. This allows you to add ground rods around your fence line and can provide a shock when a horse touches both a negative strand and a positive strand at the same time.

3) Use Recommended Materials

Do not use make-shift insulators, ordinary electrical wire, or materials we do not recommend. Copper clad ground rods, copper split-bolt connectors and copper lead-out wire prevent corrosion due to electrolysis, provide optimum electrical conductivity, reduce maintenance and increase the life of your fence.

4) Check your Fence Regularly

Don't wait for something to go wrong. Check the voltage on your fence regularly using a digital fence voltmeter. Track down and correct any electrical shorts. Check the tension on the Braid™ on a regular basis to ensure each strand is tight – posts can move due to frost heave or impact – re-set the post and re-tighten each strand.

5) Consider installing an ElectroBraid Fence Minder™

An ElectroBraid Fence Minder™ can monitor the operation of your ElectroBraid™ Fence System. If it detects a sudden drop in voltage, it will instantly alert you by siren and/or by auto-dialling your choice of phone numbers (see the ElectroBraid Fence Minder™ Manual, call 1-888-430-3330 or visit www.electrobraid.com).

**FOR THE SAFETY OF YOUR ANIMALS ALWAYS KEEP YOUR FENCE ELECTRIFIED.
NEVER LEAVE ANIMALS UNATTENDED WITHIN A NON-ELECTRIFIED FENCE.**

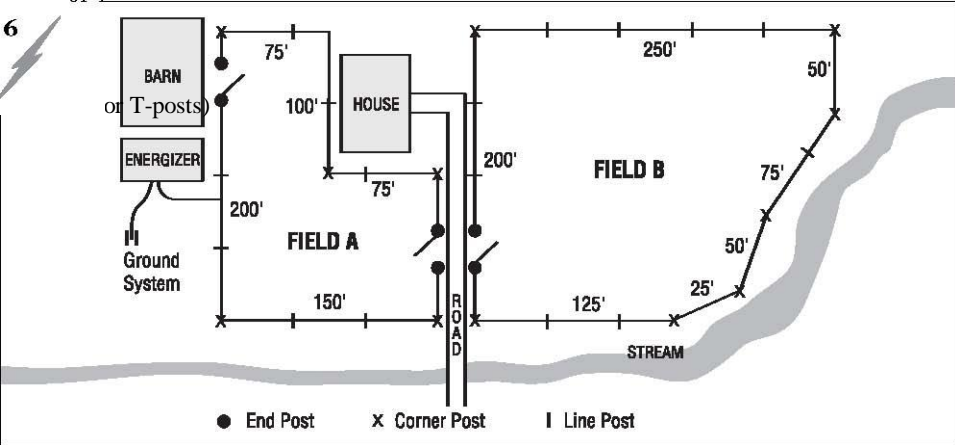

Planning your ElectroBraid™ Fence

Take the time to plan: The installation of any fencing system begins before the first post is driven. The secret to getting the best value for your dollar is to take the time to thoroughly plan before you start construction.

Check Local Laws and Ordinances: laws governing fences and electric fencing vary from county to county. Get the answer to questions such as: “How far must a fence be from a roadway?”, “Can an electric fence be used in a suburban area?”, and “Are warning signs required?”. Check with your County Extension Office or your City Clerk’s office.

Sketch a map:

Begin by drawing a map of your property, including all major features: buildings, roads, fields, swamps, woods, gullies, streams and other features. Be sure to include: power, telephone, gas and oil lines as well as underground cables.

- Mark the location of each End and Corner post
- Mark the location of each Line-Post based on the spacing you wish to use
- Mark the location of the energizer close to an electrical outlet (solar powered energizer may be used)
- Calculate the total length of your fence
- Choose the number of strands you wish to use. We recommend 3 or 4 strands.
- Choose the type of line post you wish to use (wood, vinyl, fiberglass, steel,

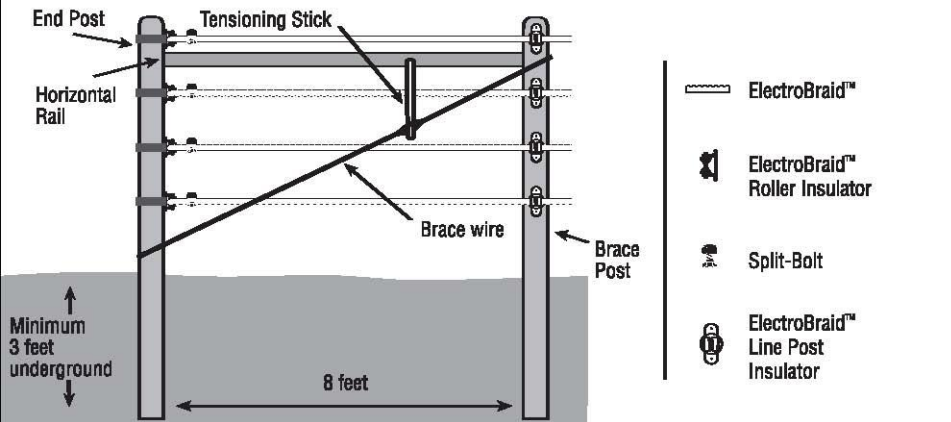

What you will Need

ElectroBraid™ is a tension system. End posts and corner posts should be braced as follows:

ElectroBraid™ Reels:

1. Multiply the length of your fence by the number of strands you wish to use and divide by the length of reel you will be purchasing = _____. This is the number of reels you will need.

ElectroBraid™ Roller Insulators for End Posts, Corner Posts, Dips and Rises:

1. Add the number of Corner posts and the number of end posts and multiply by the number of strands = _____.
2. Count the number of line posts with vertical changes in direction (hills, gullies, etc) and multiply by the number of strands = _____.
3. Add these two numbers together _____ + _____ = _____. This is the number of ElectroBraid™ Roller Insulators you will require.

Line Post Insulators for Brace Posts at Ends and Corners:

1. Multiply the number of end posts by the number of strands = _____.
2. Multiply the number of Corner posts by the number of strands and multiply by two = _____.
3. Add these two numbers together = _____. This is the number of Line Post Insulators you will require for Brace Posts.

Line Post Insulators for Line Posts:

1. Count the number of line posts and multiply by the number of strands
= _____. This is the number of line post insulators you will need for line posts.

Depending on the type of line posts you plan to use, these may be the same or a different insulator from the Line Post Insulator you plan to order for your Brace Posts (see above).

Insulated Copper Lead-Out Wire:

1. Add the widths of all your gates together and multiply by the number of strands = _____ + 6' x number of strands = _____.
2. Measure the distance from your Energizer to the nearest point on your fence = _____.
3. Measure the distance from your Energizer to where your ground rods will be located = _____.
4. Add these numbers together = _____ plus a minimum of 20' for the distance between ground rods = _____. This is the length of lead-out wire you will need.

Consider buying extra wire for possible additional ground rods and/or changes in your fence design

Copper Split-Bolt Connectors:

1. Count the number of end posts and multiply by the number of strands = _____.
2. Count the number of fence lines that exceed 1200 feet (the reel size you purchased), multiply by the number of strands and multiply by two = _____.
3. Add one split-bolt for each electrical connection.
4. Add these two numbers together = _____. This is the number of split-bolts you need.

Energizer:

Select a suitable Energizer from the chart in this manual or call us to discuss.

Ground Rods:

You will require at least 3 ground rods and probably more if your fields are large or your soil conditions are poor.

Tensioning Kit:

You will need at least one and possibly two ElectroBraid™ Tensioning Kits to tighten the Braid™.

More Information:

ElectroBraid™ and our dealers are here to help.

For more information on different fencing configurations, special considerations or combination fence designs, please contact us at:

www.electrobraid.com Call 1-888-430-3330 or e-mail info@electrobraid.com

Tools Required

To install your ElectroBraid™ Fence you need the following tools:

- ElectroBraid™ Tensioning Kit • Hammer
- Handheld Post Pounder* • Spade or Shovel
- Black Electrical Tape • Measuring Tape
- Utility Knife or wire cutters • Cigarette Lighter
- Two Ratchet Handles with Sockets • Broom Handle (for unwinding Braid™)
- Adjustable wrench • Safety glasses
- Spirit level

** For Ground Rods, T-Posts and Geotek's Fiberglass In-Line Posts you will have to purchase a post pounder from your local agricultural supply store.*

NOTE: The Geotek Mule corner, end and dip posts require a Mule Anchor Install Tool.

Getting Started – Line Spacing

With ElectroBraid™ fence you are building the equivalent of a “boxing ring”. The corner and end posts must be strong enough to withstand the forces that would be transmitted if a horse were to strike the fence at speed.

Set the bottom strand at 18" to 26" above the ground.

Set the top strand at 48" to 54" above the ground.

Space the remaining strands equally. For 4 strands, you might space at 18", 30", 42" and 54". For 3 strands, you might space at 24", 36" and 48".

Installing Corner and End Posts/Braces

ElectroBraid™ is a tension system, which requires proper bracing. For proper performance, ensure each of the following are soundly and properly braced:

CORNERS – Any change in direction greater than 20 degrees should be considered a corner and properly braced.

ENDS – You normally have an end post where you terminate or start a fence:

- For a gateway.
- To divide an existing paddock into sections (cross fencing).
- To start or terminate a run (e.g. the side of a barn).

IN-LINE BRACING – Whenever you fence a long, straight run you should install a brace post every 2400 feet.

Proper bracing will increase the effectiveness of your fence and reduce maintenance caused by post shifting. Incorrect or insufficient bracing will lead to fence failure and may be dangerous to your horses. If you are unsure of how to brace and/or your soil conditions please call us at 1-888-430-3330 for assistance.

After properly clearing the area you intend to fence, install all corner, end and gate posts. We recommend your posts be at least 5" to 6" in diameter (pressure treated for longevity). How deep to sink the post depends on the kind of soil and the exposure to frost in winter.

Posts should be set a minimum of 3 feet into the soil. In areas where ground does freeze, posts must be set to extend below the frost line. Failure to do so may cause your posts to shift, allowing the tension on the Braid™ to relax. In loose soil conditions such as sand or mud, consider cementing your posts or driving them deeper.

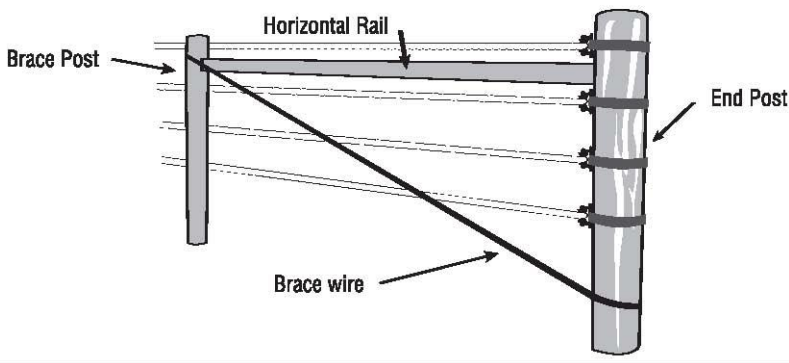

H-Brace

For most installations, we recommend a style known as the Horizontal or H-Brace. After setting your corner post, end post or gate post in the ground at the proper depth for your soil condition, measure 8' down the fence line to locate where to place your brace post. Once it is securely placed, set your horizontal rail, half way between the planned location of your top two strands of Braid™ (see diagram). Drive a spike through the back of the posts and into the horizontal rail. Leave the spike to protrude 1/2" at the back of the brace post to hold the brace wire. The spike should go through the brace post and penetrate at least 3"-4" into the horizontal rail.

If your corner, end or gate post is large in diameter, you may want to pre-drill a hole for the spike through the post and into the end of the rail.

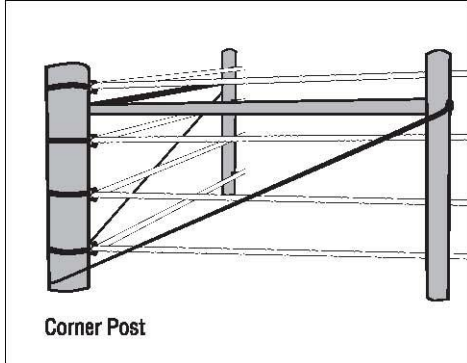
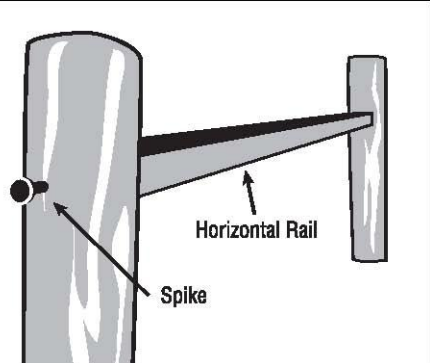

11

After your posts and horizontal rail have been set you can now set your brace wire. Use a piece of ElectroBraid™ and loop it around both posts, going from the bottom of the end post to the top of the brace post. Pull the ends together and fasten them by tying a knot or with two copper split-bolt connectors (See Splicing ElectroBraid™ page 20). Set a nail at an appropriate location on the end post so the brace wire will not slide up and, similarly on the brace post, so the brace wire will not slide down. To tension the brace wire, slide a piece of wood, such as a 3/4" dowel between the two strands of the wire and twist until taut. Fasten the dowel to the horizontal rail to keep it secure.

NOTE: To prevent an electrical short, make sure the brace wire cannot contact any ElectroBraid™ strands.

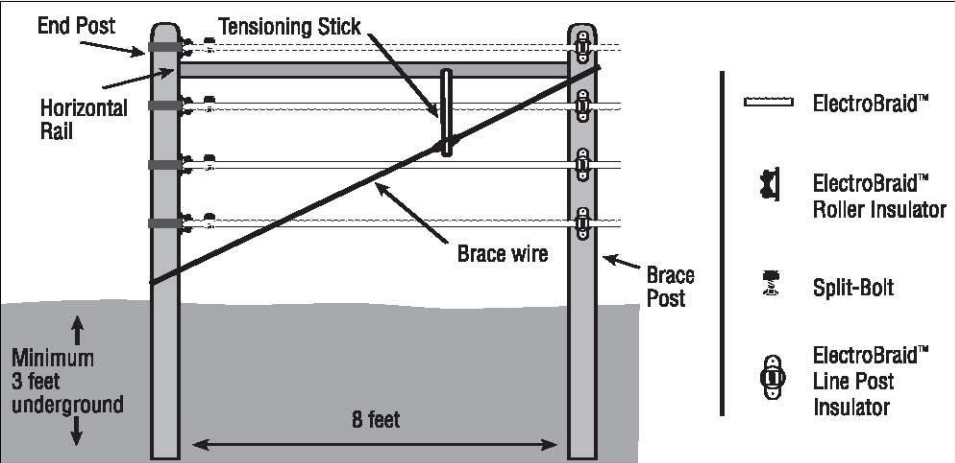

Installing Insulators on Corner, End and Gate Posts

After setting all corner, end and gate posts and correctly bracing them, you are ready to fasten insulators. Since wood conducts electricity, you must use insulators on all posts, including brace posts, to eliminate electrical shorts.

Use ElectroBraid® Roller Insulators. They are specially engineered:

- To reduce friction when tensioning
- For safety
- For durability
- For ease of installation

Measure and mark the location of each of your planned strands of Braid™ on one of your end posts. Then make a jig to help you mark your other posts (a jig is simply a stick on which you indicate the position of each insulator so you don't have to measure at every post).

There are two methods for attaching ElectroBraid™ Roller Insulators: You may simply screw the insulator in place with 2 1/2" stainless steel screws or alternatively you may use webbing as follows ...

Place the insulator on its designated mark and lightly tap a nail through a hole in the insulator to hold it in place. Only lightly tap the nail in place, as you will later remove this nail. On end posts the insulators should face the line of the fence. On corner posts the insulator should face inwards, bisecting the angle of change.

When the insulator is suspended in place, thread a piece of polyester webbing through the insulator and around the post. Overlap the webbing by at least 3". Cut the webbing and singe both ends with a lighter to prevent the webbing fibre from fraying. Use two stainless steel screws to secure the webbing to the back of the post where the webbing overlaps. When the webbing is secure, remove the temporary nail. Removing the nail frees the insulator and allows it to pivot and adjust to the contour of the land when you tension the ElectroBraid™.

Complete the installation of insulators on your corner and end posts using the jig for spacing.

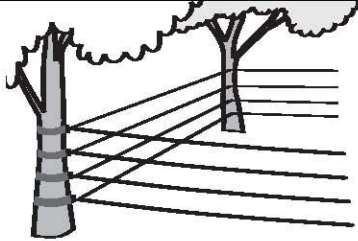

Simply attach ElectroBraid™ Roller Insulators to trees as you would a wooden post.

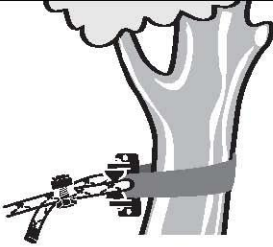

Tree as End Post

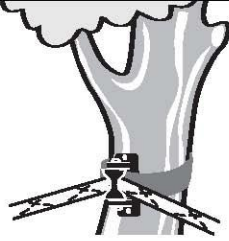

Tree as Corner Post

Installing ElectroBraid™ Roller Insulators on Inside Corners:

The preferred method is to terminate the Braid™ at each Inside Corner and then re-connect the Braid™ with copper lead-out wire. An alternative is to use two ElectroBraid™ Rollers around the back of the post, as shown in the diagram.

Using Trees For Corner, End and Line Posts:

If you are running ElectroBraid™ through a mature wooded area, you may want to use standing trees for posts. A mature tree can provide an excellent brace. Ensure you leave at least 1 foot of space between the insulator and the tree trunk to prevent the roller from wearing the Braid™ as a result of the tree swaying back and forth in the wind.

NOTE: Remove any brush that may come in contact with the fence.

WARNING: Avoid small trees that can move in the breeze and wear the Braid™.

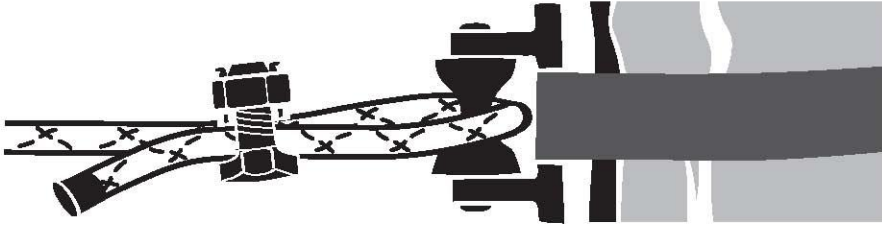

Starting at an end post, feed the leading end of the ElectroBraid™ through the Insulator and secure it to itself using a copper split-bolt connector. The split-bolt should be about 2" from the end insulator. Leave at least 2' of Braid™ outside the copper split-bolt connector. Tape, cut and singe the end to prevent fraying.

Installing Line Posts

When you have completed the corner and end posts, you are ready to install your line posts and line post insulators and start running your lines.

First you need a sight line. Starting at a gate or end post, feed the ElectroBraid™ through the second insulator from the bottom and secure it using a copper split-bolt connector. Pick up the reel and begin to walk the fence line. Insert the ElectroBraid™ behind each corner post insulator. When you get to the end post, insert the ElectroBraid™ behind the end post insulator and secure it with a split-bolt. Attach the tensioning device and tighten (see Tensioning ElectroBraid™ page 18). Then loosen the split-bolt, pull out the slack and re-tighten. The sight line you have created will help you position your line posts in a straight line.

On hilly terrain, install line posts at the peaks and in the valleys first. Then space the remaining line posts to suit the terrain. *An ElectroBraid™ Roller Insulator is recommended where there is a horizontal or vertical change in direction. The use of other insulators could allow the Braid™ to pull out under tension.*

NOTE: Always work with the "lay" of the land. Place a post at the top of each rise and the bottom of each depression. Recommended distance between line posts is 30 to 50 feet. Reduce post spacing in hilly terrain and in areas of winter conditions.

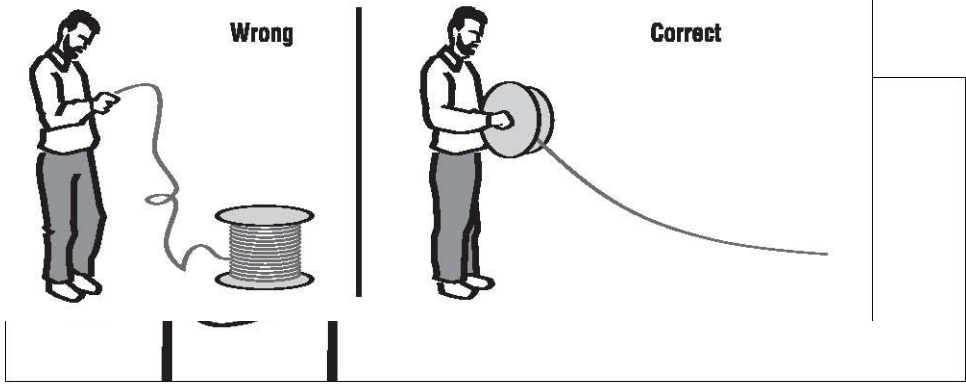

16

Call us Toll Free: 1-888-430-3330

Installing Wood Line Posts:

Using the installed strand of ElectroBraid™ as a sight line, set your line posts. Mark the position for each insulator with your jig, and attach each line post insulator and each ElectroBraid™ Roller Insulator to all posts.

NOTE: The ElectroBraid™ Roller Insulator will withstand a greater force from a vertical change of direction than a conventional line post insulator. To install the Braid™ on a line post at a peak or a valley, first tension the Braid™. Then, after the Braid™ has been tensioned, remove the roller pin, place the Braid™ behind the roller and re-insert the pin. The Braid™ may jam in the insulator if you insert the Braid™ behind the roller and then try to tension.

Installing T-Post Line Posts:

Lay out all your posts and mark each one for the depth to drive the post and the location of each insulator. Using the first strand of Braid™ as a sight line, use a post pounder to set your T-Posts, (IMPORTANT: be sure your T-Posts are correctly oriented (the flat side of the T-Post should be on the inside of the paddock) so the Braid™ will be on the inside of the paddock when attached to the insulators. Then attach your T-Posts insulators.

NOTE: A T-Post Cap provides an insulator for the top strand and also reduces the hazard of a horse being speared by a T-Post.

Installing Geotek Fiberglass Line Posts:

Lay out all your posts and mark each one for the depth to drive the post into the ground, and for clip locations. First, slide the appropriate number of clips on each post, then use your post pounder to set the post in the ground. CAUTION: It is possible to mushroom the top of the post with the post pounder which will prevent you from sliding the clips onto the post.

Running your Lines

Pick up the reel and walk your fence line. At each line post, fasten the strand of ElectroBraid™ to each insulator.

DO NOT take Braid™ off one end of the spool. The Braid™ will kink and could be damaged. The correct method is to unreel the Braid™ and it will not kink (see diagram). Continue unreeling the Braid™ until you come to an end post where the strand will terminate. End the strand by attaching it to the end post insulator just as you did when you started the strand. Pull hard on the Braid™ to remove as much slack as you can before you apply the tensioning device. Clamp the ElectroBraid™ to itself using a copper split-bolt connector approximately 2" from the insulator.

NOTE: When installing fence on rolling terrain tension all lines first before attaching the Braid™ to the dip and ridge posts.

Dip Post

A Better Way to Fence Your Horse

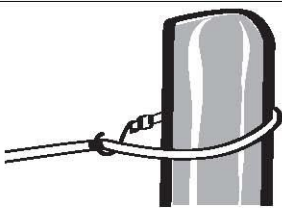

Wrap the end of the ratchet rope with the "S" Hook around the post and fasten it to the ratchet rope.

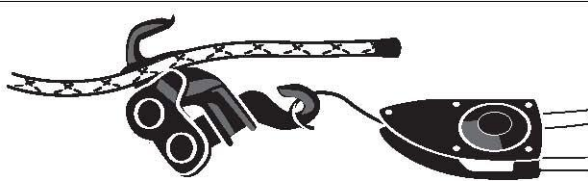

Position the clamp on the strand you are tensioning and attach the clamp to the "S" hook on the ratchet as shown.

17

A Better Way to Fence Your Horse

17

Tension Kit Assembly

Tensioning ElectroBraid™

After a strand of Braid™ is installed you can apply the ElectroBraid™-tensioning device.

Pull as hard as you can. Do not tension the Braid™ with a tractor, come-along or other mechanical device. The ratchet can handle 250 lbs. before it will slip, so *do not worry about over-tensioning when tightening by hand*. The single strand breaking strength of ElectroBraid™ is over 1300 pounds. When you can't pull anymore, loosen the copper split-bolt connector, pull out the slack you have created and re-tighten the split-bolt connector.

CAUTION: ALWAYS USE EYE PROTECTION WHEN TENSIONING. It is possible for a split-bolt to slip and/or an insulator to break. They can become dangerous projectiles.

Wrap black electrical tape around the Braid™ before you cut it. Use a utility knife or wire cutters to cut the ElectroBraid™ and then singe both ends with a lighter.

NOTE: Always tape before you cut. Always singe the end until it melts so the rope won't fray.

Loosen and remove the tensioning device and return to the post at the beginning of the strand. Just as you tensioned the Braid™ where you terminated the strand, tension once again at the post where you began. Tensioning from both ends helps to ensure you get full and even tension on the line

NOTE: Let the ElectroBraid™ sit for 24 hours after initially tensioning and then re-tension each strand again. Re-tensioning after 24 hours completes the tensioning process.

ElectroBraid™ maintains its tension very well so you will not have to constantly re-tension. However, if one of your posts moves due to frost or the impact of an animal or vehicle, the ElectroBraid™ will need re-tensioning. Re-set the post and apply the tensioning device to re-tighten the Braid™. Consider strengthening your bracing to ensure the post won't shift again.

If you are fencing a paddock or pasture larger than one acre, we recommend you tension from corner to corner. To do this you will require a second tensioning kit. Starting at an end post, walk the perimeter until you come to the first corner. Tension this corner.

Go to the next corner and repeat the process. After tensioning, return to the first corner and remove the ratchet. Repeat this process until you have tensioned the entire perimeter of your fence.

Remember you must terminate the ElectroBraid™ after every 2400 feet. Do this by installing an In-Line H-Brace. (see page 11)

For large pastures.

Tighten at each corner post.

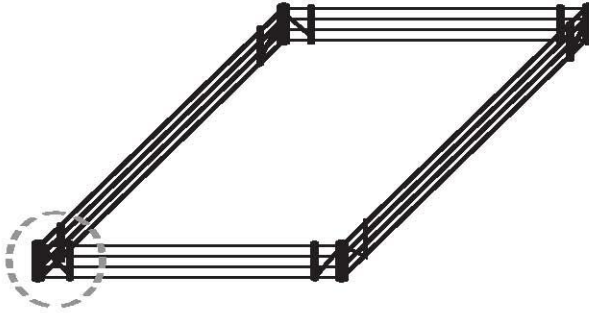

Tighten, clamp and terminate at in-line brace posts.

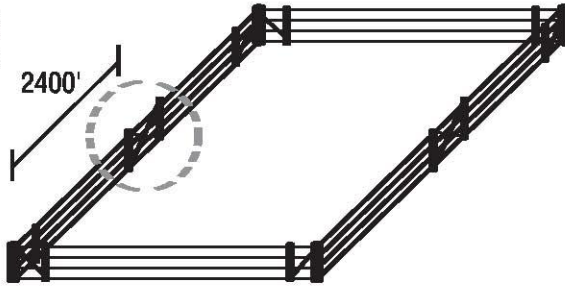

Splicing ElectroBraid™

When you end one reel of ElectroBraid™ and start another, you will have to splice the two reels together. Simply overlap the two ends of ElectroBraid™ about 4" and then use two copper split-bolt connectors to secure them together. Ensure there is direct contact between the copper strands in each strand of Braid™. Make sure you tape and singe both ends of Braid™.

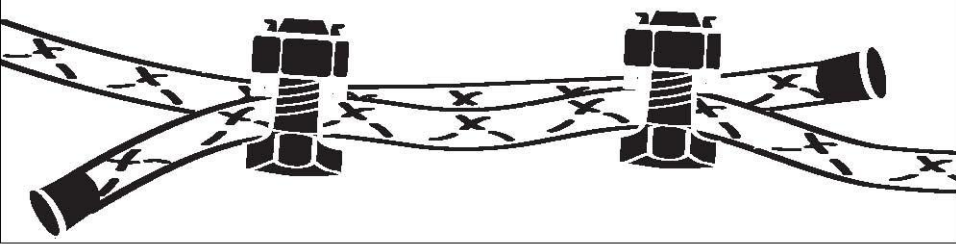

Call us Toll Free: 1-888-430-3330

Miles	ElectroBraid	Speedrite	Pel	Stafix	Gallagher	Zareba	Parma k
1/2	2.5 Joule	Delta 2	Pel 215	M1.2	M250	A25L1	M3.2
1	2.5 Joule	Delta 2	Pel 215	M2.5	M250	A25L1	M6
2	2.5 Joule	Delta 3	Pel 230	M6	M500	A50L1	M6
3	2.5 Joule	Panther 5800	Pel 605	M12	M1000	A100L1	M6
5	6.0 Joule	Panther 9800	Pel 609	M12	N/A	A200L1	M12
8	11.0 Joule	Panther 12000	Pel 632	M12	N/A	N/A	M12
12	18.0 Joule	Panther 20000	Pel 632	M36R	MR 1800	N/A	M18
15	N/A	Panther 25000	Pel 632	M36R	MR 2500	N/A	M18
22	N/A	Panther 36000	Pel 632	M36R	N/A	N/A	M36

Solar Powered Energizers:

Miles	ElectroBraid	Speedrite	Pel	Stafix	Gallagher	Zareba	Parma k
1/2	N/A	Delta 1B	210B	SX Solar	B75	SP3	Mag 12-SP
1	N/A	Delta 1B	210B & 220B	B1.5	B160	SP10 & SP30	Mag 12-SP
2.5							Mag 12-

Electrifying the Fence

Choosing your Energizer

It is vital that the energizer you choose has sufficient power to meet your needs. The marketing of electric fence energizers is extremely competitive and manufacturers wildly overstate the length of fence each energizer can adequately electrify. A simple rule of thumb is to match your length of fence to 1/10 the energizer's rating. Part of the reason is that you will be electrifying 3 or more strands of Braid™.

Mains Powered Energizers (110 Volts):

WARNING: Only use a LOW IMPEDANCE energizer that is UL or CSA approved. NEVER use an Energizer labeled "WEED BURNER" or "WEED CHOPPER"; they are unsafe and WILL damage ElectroBraid™.

WARNING: Never use regular house wire or ElectroBraid™ for your electrical connections. Only use high voltage, heavily insulated, copper lead-out wire, copper clad ground rods and brass ground rod clamps.

NOTE: To protect your mains energizer investment, we recommend a surge protector between the power source and your energizer.

Ground System:

First decide where to locate your energizer (also known as a “fencer” or “charger”). You can use a solar powered energizer or an AC mains powered energizer (110 Volts), but a mains energizer is always more reliable. Your AC mains energizer should be mounted on a wall indoors, away from flammable material and out of reach of children.

We recommend a minimum of three, 6 foot, copper clad ground rods spaced at least ten (10) feet apart in a triangular configuration. Look for soil that is wet or moist year round to place your ground rods. Dry, rocky, sandy or frozen soils may present special problems – electrons do not readily pass through such soils and the intensity of the shock may not be sufficient to deter an animal from touching the fence. More ground rods may be required. These can be placed as needed along the fence line. Call 1-888-430-3330 to discuss special grounding problems with us.

Ground rods should be placed at least twenty-five (25) feet from your energizer and near the fence line, but at least 50 feet away from any underground piping, cable or other grounding system. A ground rod closer than 50 feet from a waterline (even if the waterline is plastic) may cause signal interference in your home computer, phone, radio or TV. Ground rods closer than 25 feet from the energizer may damage the energizer during electrical storms.

Remember to attach clamps BEFORE driving ground rods as the end of a ground rod may mushroom from pounding, making it impossible to slide a clamp over the end.

When you have installed your ground rods, connect them with heavily insulated copper lead-out wire rated for at least 15,000 volts. Strip 3/4" of the insulating jacket and crimp a ferrule on with pliers. Secure with cable ties for a trouble-free, permanent installation (see diagram).



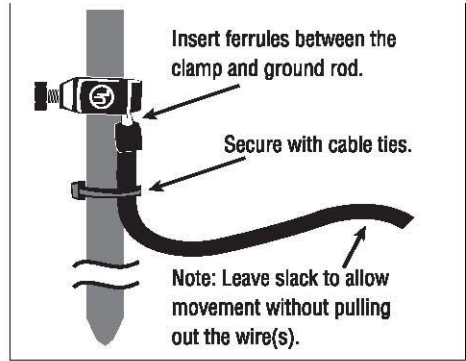
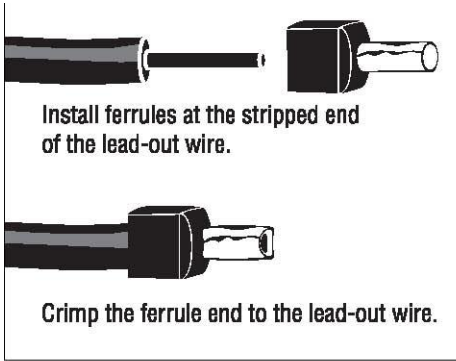

22

Call us Toll Free: 1-888-430-3330

Secure connecting wires to the ground rods with brass ground rod clamps. Add cable ties for increased security. After all ground rods are connected, connect one ground rod to the negative terminal on your energizer.

Do not confuse ground rods for your house with ground rods required for an electric fence energizer. The ground rods used with a fence energizer act as receivers for electron flow.

Grounding is one of the most critical elements in any electric fence system. Over 95% of all electric fence problems result from poor grounding.

It is important to understand how and why you need an effective ground system.

For an electric fence to provide an effective shock, an electric circuit must be completed. That means the electrons passing along the fence must pass through the animal and then return back to the energizer. The electrons can return to the energizer either by travelling through the ground to the ground rods or through the negative (grounded) strand on your fence, which is connected to the negative terminal on the energizer.

We always recommend a negative (grounded) strand on your fence. No matter how dry the soil condition, a negative strand on your fence will deliver a shock to any horse that touches both the negative (grounded) strand and a positive strand of Braid™ at the same time.

NOTE: Bury the ground rods so the connecting ground wire is below the surface of the soil to avoid the risk of animals, equipment, or people breaking or disconnecting the ground wire. Use small indicator flags to show where each ground rod has been buried.

IMPORTANT: Check with local utility companies to locate existing underground cables, power lines or pipes before you install your fence posts and ground rods.

When you install a solar powered energizer, position it away from shadow or possible animal contact. Face the solar panel towards the equator or at an angle to allow maximum exposure to the sun.

TIP: Place your Solar Powered energizer out in the field for two days before connecting it to the fence. This will allow the battery to charge to its maximum capacity. Ensure the unit is turned "Off" while charging (failing to fully charge a battery before use will prevent the

battery from ever reaching a full charge).

Wiring your Energizer:

You can now connect your energizer to the ElectroBraid™. Run a length of copper lead-out wire from the positive terminal on your energizer to the top strand of Braid™. Feed the copper wire into a copper split-bolt, which is fastened to the strand, making sure the wire has direct contact with the wires in the Braid™.

WARNING: Never loosen the split-bolt connector without first taking the tension off the line you want to electrify. Use the ratchet and clamp to release and hold the tension before releasing the split-bolt.

NOTE: For easier troubleshooting, it is best to use an extra split-bolt connector for electrical connections. Then if, you need to disconnect the wiring from a strand you will not have to use the tensioning device to hold the tension.

NOTE: Use of cable ties will prevent lead-out wire from breaking due to vibration.

After the tension has been taken off the line you are electrifying, feed the copper wire from the energizer into the split-bolt connector. While you have the split-bolt connector loose, cut and insert another piece of insulated copper wire that will be used to jump the electricity to the third strand (Note: Skip the second-from-the-top strand – it will be grounded to the negative terminal on the energizer or to the ground system). Repeat for the fourth strand (this technique will allow you to easily disconnect the lower line(s) in case of heavy accumulation of wet snow which may cause the fence to short). Before inserting, pre-measure the proper length of the jumper wires and strip away 1" of insulation so the copper in the lead wire is exposed to ensure a good connection. After all leads have been connected, re-tighten the split-bolt, release the ratchet and attach cable ties. Bury all wiring 8"-10".

*NOTE: We recommend you thread all underground **positive** wiring through a piece of 3/4" conduit (flexible Poly well water pipe) to avoid abrasion and to prevent shorting between negative and positive wires. Bury the pipe 8"-10" deep. Strap the ends of the pipe to the gate posts with the ends turned down to prevent rain and dirt from filling the pipe.*

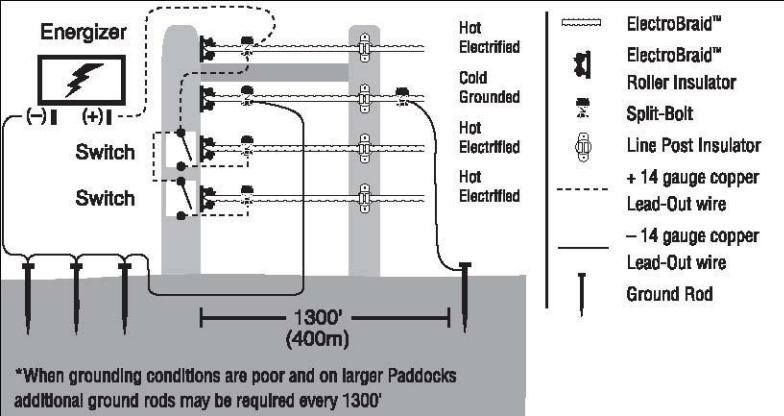

Standard Energizer Fence Wiring Diagram

Negative ("Grounded") Positive ("Hot")

Wiring the Energizer for Areas of High Snowfall

Negative ("Grounded") Positive ("Hot")

NOTE: Switches should be set above snow height. NOTE: Wires should be fastened to post to protect them from damage.

Heavy wet snow can short electric fencing. To prevent this, fences in areas prone to snow accumulation can be wired as illustrated.

Cut-Off switches can be installed to allow you to progressively turn on and off the bottom Standard Energizer Fence Wiring Diagram strands with the changing depth of snow. Wire your energizer as shown in the diagram.

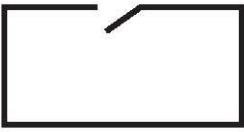

This fence doesn't require wiring underneath the gate because no section of fence is isolated.

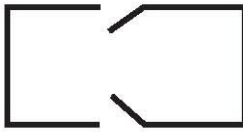

In each of these cases one gate will require underground wiring to carry the separate positive and negative circuits from the section that is electrified to the section that is isolated.

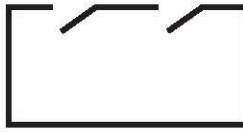

When to Wire Gates

When do you have to wire under a gate?

Wiring Gates

Dig a trench under your gate. If it is a narrow, walk through gate, 4"-6" deep will suffice. However, if heavy equipment, such as trucks or tractors will be going through the gate, the trench should be 8' to 10' deep.

*NOTE: We recommend you thread all underground **positive** wiring through conduit (a piece of 3/4" flexible, Poly well water pipe) to avoid abrasion and to prevent shorting between negative and positive wires. Bury the pipe 8"-10" deep. Strap the ends of the pipe to the gate posts with the ends turned down to prevent rain and dirt from filling the pipe.*

NOTE: The insulation on the underground wire should not breakdown at less than 15,000 volts. If the guard voltage is less than 15,000 volts, the wire may leak electricity, which will affect the integrity of your fence. Your animals may not want to cross over the buried wire if they sense electricity beneath them.

Connect a piece of copper insulated lead-out wire to one of the strands by connecting the wire to the Braid™ with a copper split-bolt connector. Run the wire underground and re-attach it to the strand on the opposite side of the gate, using another split-bolt connector. Then, to electrify additional strands, jump the electricity, vertically, from that strand to other strands to be electrified, as illustrated.

Use a second length of wire to connect the negative (grounded) second-from-the-top strand of Braid™ to the second-from-the-top strand on the other side of the gate. Secure all wiring to the post to prevent damage.

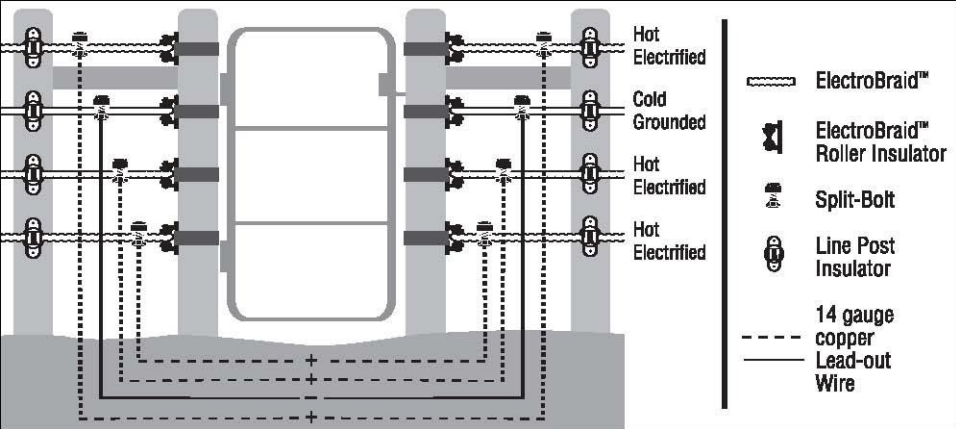

Standard Gate Wiring Diagram

Wiring Gates in Areas of High Snowfall

NOTE: Wires should be fastened to post to protect them from damage.

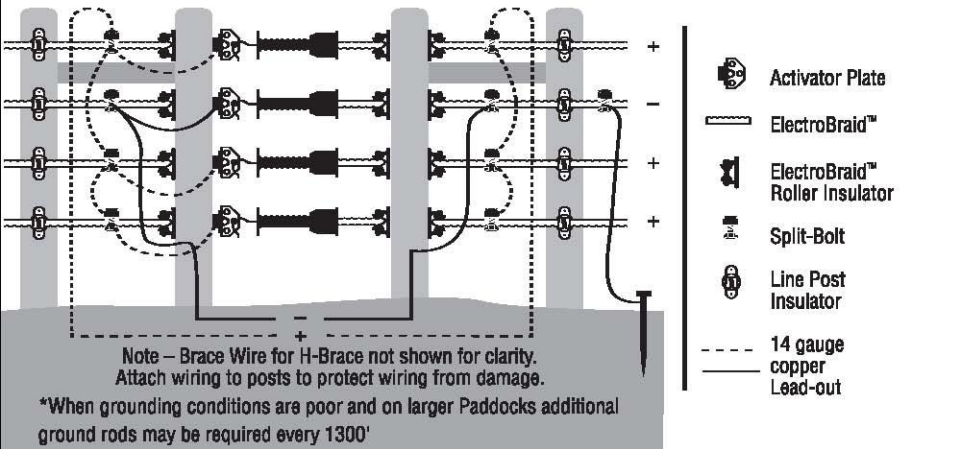

Using Gate Handles for Gates

Gate handles allow you to build the perfect, cost effective, 15 to 20 foot wide gate for infrequent use. They give easy access for bringing heavy equipment in or out of paddocks for seeding or fertilizing.

NOTE: Never recommend for horses. The activator plate can cut a horse.

Latch Side of Gate:

- 1 Wire the gate as described in the section "Wiring Gates."
- 2 Install the activator plates on the gate post at the same height as each strand of Braid™.
- 3 Use a short length of 14 gauge copper lead-out wire to jump from each strand of Braid™ to each activator plate.

Hinged Side of Gate:

- 1 Install an ElectroBraid™-Roller Insulator on the "hinged" side of the gate post at the same height as the opposing strand.
- 2 Attach a length of Braid™ (about the width of the gate) to the ElectroBraid™-Roller Insulator with a copper split-bolt connector.
- 3 Hook the gate handle onto the activator plate. Secure the Braid™ to the spring inside the gate handle by taking two wraps around the spring and securing with a copper split-bolt connector.

NOTE: When using trees, mount activator plate on a 2"x4" and attach to tree to prevent damage from tree growth.

Wiring Cross Fencing Sections (paddock division)

Unlike gates, there is no need to dig a trench. Simply connect the power from the perimeter fence to the section of cross fencing using lengths of copper lead-out wire.

Testing the Voltage on Your Fence

Testing that your fence is working properly is simple...

First, go to the point of your fence which is most distant from your ground system and read the voltage between the second-from-the-top grounded line and each of the other electrified fence lines to confirm that the fence is wired properly with no electrical shorts. **Then and most importantly, check the voltage between each electrified fence line and the soil under the fence.** Place the ground pin on the voltmeter about a half inch into the soil and test the actual voltage of each positive line. Finally, check the voltage to the soil at any high points or dry areas in the paddock to make sure you are getting at least 5,000 volts. If all readings are over 5,000 volts, your fence is working properly.

These simple tests will assure you that your ElectroBraid-fence is properly installed. Please monitor your fence on a regular schedule.

TIP: Test after rain when conditions are wet to best determine if there are any electrical shorts. Shorts are more easily detected in wet conditions.

TIP: Test when conditions are very dry to confirm that you have adequate grounding. In particular, test where the fence runs over high terrain or through areas that might be especially dry.

TIP: Listen for crackling sounds or look for arcing at night to locate any shorts in your fence.

Diagnosing Electrification Problems

If readings are under 5,000 volts, follow these steps to diagnose the problem:

NOTE: These are general guidelines only. For more specific information on troubleshooting your particular problem, please do not hesitate to call our free, 7 day a week technical support line at 1-888-430-3330.

1. Turn your fence energizer OFF.
2. Disconnect the two lead out wires from your fence energizer.
3. Turn the fence energizer ON and read the voltage on your energizer with your voltmeter – simply apply the voltmeter to the (+) terminal and the ground pin on the wire lead of the voltmeter to the (-) terminal of the energizer. If less than 5,000 volts, there is a problem with the energizer.
4. If the energizer is O.K., turn it OFF before you reconnect the two lead out wires to the energizer, then turn the energizer back ON.
5. Now read the voltage on each strand of your fence near where the energizer is connected to the fence. Apply the ground pin on the voltmeter to the second-from-top Grounded line and apply the voltmeter to each of the other electrified Positive lines, one after the other. You should read at least 5,000 volts on each electrified line. If less than 5,000 volts, there is a problem with the lead-out wire, you have crossed wires during installation or you have electrical shorts along your fence.

6. Now go to the point of your fence which is most distant from your ground system. First, read the voltage between the second-from-the-top grounded line and each of the other electrified fence lines to confirm that the fence is wired properly with no electrical shorts. **Then and most importantly, check the voltage between each electrified fence line and the soil under the fence.** Place the ground pin on the voltmeter about a half inch into the soil and test the actual voltage of each positive line. If less than 5,000 volts, you have a problem with your ground system. See instructions on how to “Test the Earth Return System”.

7. Finally, check the voltage to the soil at any high points or dry areas to make sure you are getting at least 5,000 volts. If less than 5,000 volts, you will need to install additional ground rods.

REMEMBER: ALL READINGS SHOULD BE OVER 5,000 VOLTS

If any reading is less than 5,000 volts, you need to troubleshoot and fix the problem. If you can't fix the problem, call us at 1-888-430-3330 and let us help you.

Testing the Earth Return System of your Fence

- 1 Turn the fence energizer OFF.
- 2 300 or 400 feet from the fence energizer, create a short circuit of the current in the fence by laying two or three steel stakes or lengths of pipe against the lowest, hot line of the fence, preferably where the ground is damp. **DO NOT ALLOW CONTACT WITH THE GROUNDED SECOND-FROM-TOP LINE OF BRAID™**— it is important that the electrical current flow freely from the electrified fence lines into the Earth Return system.
- 3 Turn the fence energizer ON.

If you have a Digital Voltmeter ...

- 1 Apply the voltmeter to one of your ground rods. Apply the ground pin to a small steel stake (such as a screwdriver) placed in the ground at least 3 ft from any ground rod.
- 2 The reading on the voltmeter should be 0.3 k volts (300 volts) or less. If it is greater than 300 volts, the ground system is inadequate. You may need more ground rods.

If you have a 5 light tester ...

You cannot check the grounding with a 5-light voltmeter because it cannot read less than 1000 volts. The following procedure can be used:

- 1 Wearing plastic or rubber footwear, place one hand on the last ground rod and, then, with one finger of the other hand, touch the nearest blade of grass. If you feel no tingling sensation, place your hand gently, then firmly on the ground. If you still feel no tingling, the grounding of your fence is good.
- 2 If you experience tingling, better grounding is required and you'll need to add more ground rods.

Trouble Shooting

No Respect: If you find your horses are showing less respect for their fence than normal, it is very likely something is reducing the voltage on your fence, or the grounding of the fence is not what it should be.

Here are some things you should do:

- Follow the instructions on “Testing your Fence”.
- Check all electrical connections to ensure they are secure.
- Check that the ground rod clamps are secure and connector wire is intact.
- Walk the fence line to ensure nothing has happened to cause the fence to short out.
- Are your horses standing on ground that is so dry or frozen that they are insulated and prevented from getting a shock? Is this a general problem, or is it localized?
- If grounding is the problem, take steps to improve grounding

If you have any difficulty diagnosing why your fence voltage or grounding is not as it should be, please do not hesitate to call us at 1-888-430-3330 and let us help you solve the problem.

Loss of Tension: If you detect a loss in tension, check the following:

- A post may have moved at a corner, end or gate.
- A copper split bolt connector may have slipped and needs to be tightened.
- Broken insulator

Installing an ElectroBraid Fence Minder™

Your ElectroBraid Fence Minder™ will continuously check to make sure your fence is fully energized. It will warn you, day or night, if it detects a significant voltage drop. If a horse is in contact with your fence for more than three seconds, your Fence Minder™ will shut off your energizer to stop further electric shocks; and immediately alert you by siren and/or by auto-dialing your pre-programmed phone numbers.

If the contact between horse and fence is less than three seconds, the Fence Minder™ will not signal an alarm. Also, it is programmed so that neither rain nor snow should cause a false alarm.

If the fence voltage drops gradually below a pre-set minimum, the Fence Minder™ will alarm but not turn off the power. Such a voltage drop may be the result of electrical shorts along the fence line.

Provided you verify your fence is properly grounded, and regularly check your voltage with a digital voltmeter, your Fence Minder™ will give you the peace of mind of knowing that your ElectroBraid™ fence is keeping your horses safe.

Your Fence Minder™ can be powered by mains power (120 volts AC/60 Hz) or by battery or solar power (8-16 volts DC). Alarm devices are connected as accessories. The siren can be wired for continuous or intermittent signaling, to conform to local noise pollution bylaws. A telephone auto-dialler can also be connected. It comes with its own Operating Manual.

Please call us at 1-888-430-3330 for more information, or visit www.electrobraid.com

Do's & Don'ts – Safety and Maintenance

To keep your horses safe, use good horse sense:

- Know your horses and recognize the limitations of your property.
- Separate aggressive stallions from other horses by a laneway.
- Always introduce a horse to a new pasture. For your own safety, turn OFF the fence energizer so the horse you are leading won't get accidentally shocked and bolt. Lead the horse around the fence perimeter. Once the horse understands the boundaries of its new pasture, release the horse and turn the energizer back ON.
- Take particular care when you introduce a new horse to a pasture where other horses have an established pecking order.
- Don't torment your horses with accidental electric shocks by putting water troughs close to your electric fence, hanging grain pails on your fence posts, or throwing hay near your electric fence.
- Don't build a new fence close to where your horses roll. If necessary, relocate the fence away from where they habitually roll.
- Small paddocks can be hazardous to very active horses. They need room to roll. To fence small paddocks and pens, consider using an ElectroBraid™ Top Line with Diamond Mesh or V-Mesh or a heavy grade of 2-by-4 No-Climb.



Minimum 12'
dividing lane

33

Fence Sense:

- Install your ElectroBraid™ fence as recommended. Choose either three strands or four strands of Braid™. Set the highest strand at 48 to 54 inches and the lowest strand at 18 to 26 inches.
- Don't turn off your fence energizer to save electricity. The cost of electricity for a fence energizer is the same as a 100-watt light bulb – about a dollar a month.
- Regularly inspect your fence to ensure the Braid™ is taut and properly electrified.
- Thoroughly check the fence after heavy rain or stormy weather.
- Take particular care to make sure your fence is well grounded. **95% of all electric fence problems are due to poor grounding.** Check your installation manual or our website, or call us for advice.
- Use a hot-cold system – ground the second-from-the-top-strand of Braid™.
- Always turn the energizer off before servicing the fence.
- When testing an electric fence with a voltmeter, wear rubber gloves or rubber-soled shoes to minimize any accidental electrical shock. Wet or sweaty hands or wet feet intensify electrical shocks.
- Use only one energizer per paddock or continuous fence line. Never use two energizers on the same fence.
- Use extreme caution if you are considering installing an electric fence near overhead lines or underground power lines.
- Do not stand beside a fence during an electrical storm.
- Use warning signs to mark an electric fence every 200-300 feet.
- Never attempt to service your energizer. If it fails, seek professional assistance or send to the manufacturer for servicing.
- ElectroBraid™ is engineered for your horses' safety. Don't take shortcuts!
- Please manage your horses with care and maintain your fences. Courts hold the property owner responsible for the security of their animals.

Do not ...

- Hang feed buckets on the fence;
- Drape water hoses over the fence;
- Stack feed or manure near the fence;
- Run water lines parallel to the fence;
- Allow feed or water barrels to be located too close to the fence.

We welcome your comments and suggestions. Our Company Mission is To Build Safe Fences

**Relax and enjoy your new
ElectroBraid™ Fence!**



Hiring a Professional Fence Installer

ElectroBraid™ is a do-it-yourself fence system. Nine out of ten ElectroBraid™ customers install their fence themselves. If you want to hire a fence installer, (perhaps only to install your fence posts and gates), may we suggest the following:

Consult the ElectroBraid™ Installation Manual and decide the fence design you want: post spacing, bracing, number of lines of Braid™, etc. Consult your local Yellow Pages, or ask your friends, for the names of two or three good, local fence installers.

Ask for customer references and ask for addresses where you can inspect their work. Get at least a couple of cost estimates. If your good local fence installers are too busy, find an experienced farm hand or general handyman to help you with the heavy work. Install the Braid™ and electrify the fence yourself! Inspect your completed ElectroBraid™ fence to be sure it is solid, the Braid™ is taut, the electrical system is properly grounded, and producing at least 5,000 volts.

Any Questions? Call us Toll-Free at 1-877-300-2638. We are always pleased to help.